



**DAVIS INDUSTRIES, INC.**

**MADE IN USA**

**6" Pitch Steel Hinge Belting (#6025FLSD)**

- ✓ 9000 Pound Maximum Belt Pull
  - ✓ 1/4" thick Pans
  - ✓ 1/4" x 2" Chain Bar
- ✓ 3" Diameter x 1-1/2" Face, Hardened Sintered Steel Roller
  - ✓ Heat Treated Roller Bushings
  - ✓ 3/4" Diameter C1045 Belt Pins
- ✓ Plain, Perforated, Dimpled Pans Available
  - ✓ Cleats available to suit application

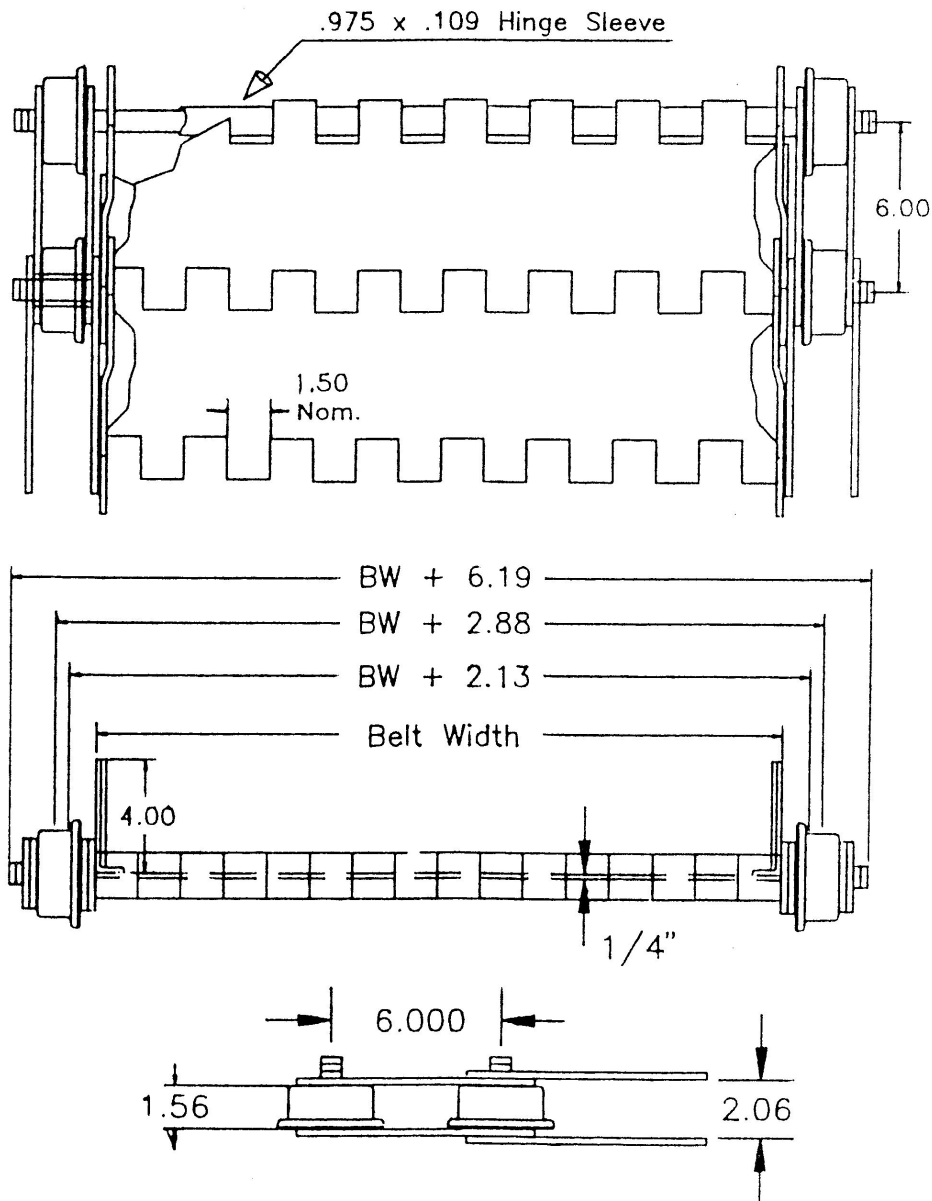

**Cleveland, Ohio USA**

**Phone & Fax: 800-577-0559 Email: sales@davis-ohio.com**

**Web: www.davis-ohio.com**